



GLOBAL



USER MANUAL

ELECTROFUSION CONTROL BOX MODEL LITTLE BEAT

Edition: October 2019

Revision: N° 5

Publication: MU-78-13EN

DATOS DEL FABRICANTE MANUFACTURER DATA	
<p>ACUSTER GLOBAL, S.L. Rambla d'Ègara, 340 4th floor 08221 Terrassa (Barcelona) - SPAIN Tel. (+34) 93 736 18 80 e-mail: info@acusterglobal.com</p>	
DATOS DEL DISTRIBUIDOR Y SAT DISTRIBUTOR AND SERVICE DATA	
<p>STP Acuster Internacional Rambla d'Ègara, 340 4th floor 08221 Terrassa (Barcelona) - SPAIN hello@stpacuster.com +34937361880</p>	<p>STP Acuster North Europe Ind. terrein de Wildeman, hof 4 Bossekamp 12 5301 LZ Zaltbommel - The Netherlands info@iwmc.be +31418840003</p>
<p>STP Acuster Central Europe 2, Kvetna 685, Areal Salvia 736 61 Napajedla - Czech Republic info@stp-fittings.cz +420577913065</p>	<p>STP Acuster Baltics Bullu str. 45 Riga, LV1067 - Latvia riga@stpfittings.lv +37167815281</p>
<p>STP Acuster South Africa 54 Richard Road, Industria North PO BOX 2203 Wilro Park 1731 Roodepoort - South Africa shawn.pretorius@stp-sa.com +27315397451</p>	<p>Agru Acuster Chile Lo Echevers 891, Bodegas 11 y 12, Quilicura, Santiago - Chile info@agrusa.cl +56229493910</p>
<p>Agru Acuster Brasil Rua Saburo Sumiya, 211 Aldeia, Barueri, SP CEP: 06440-110 - Brasil daniel@agru.com.br +55114138088</p>	



NOTES!
At the time of the publication of this <i>User Manual</i> , the software version is V. 1.9.2.
The modifications carried out against the previous revision of this publication are indicated with on the right margin.

CONTENTS:

1	INTRODUCTION.....	4
1.1	GENERAL	4
1.2	DESIGN SPECIFICATIONS	4
1.3	GENERAL INFORMATION	4
1.4	UNIT IDENTIFICATION	5
1.5	MEASURES OF PROTECTION AGAINST ACCIDENTS	5
1.5.1	<i>Safety alert symbols</i>	5
1.5.2	<i>Safety measures and dangers</i>	5
1.6	DECLARATION “CE” OF CONFORMITY	7
1.7	GUARANTEE	8
2	DESCRIPTION OF THE ELECTRONIC FUSION UNIT	9
2.1	GENERAL	9
2.2	FRONT PART	10
2.3	SIDES	10
3	MODE OF USE	11
3.1	FUSION PROCEDURE FOR ELECTROFUSION FITTINGS	11
3.1.1	<i>Scraping pipe surfaces</i>	11
3.1.2	<i>Fitting installation</i>	11
3.1.3	<i>Unit connection</i>	12
3.1.4	<i>Fitting connection</i>	13
3.1.5	<i>Entering electrofusion data in the unit</i>	13
3.1.6	<i>Incidents that may occur</i>	19
3.2	ACCESS TO SETUP MENU	21
3.2.1	<i>Display settings</i>	21
3.2.2	<i>Activation of the user authorization code:</i>	22
3.2.3	<i>Language settings:</i>	22
3.2.4	<i>Service menu:</i>	22
4	MAINTENANCE.....	23
4.1	GENERAL	23
4.1.1	<i>Introduction</i>	23
4.1.2	<i>Storage</i>	23
4.1.3	<i>Cleaning</i>	23
4.1.4	<i>Services</i>	23
4.2	CONTROL UNIT MAINTENANCE	24
4.2.1	<i>Electronic Control Unit:</i>	24
4.2.2	<i>Updating the Programme Version:</i>	24
5	TECHNICAL CHARACTERISTICS.....	25
5.1	ELECTROFUSION CONTROL UNIT	25
5.1.1	<i>General specifications</i>	25
5.1.2	<i>Generator specifications</i>	26
5.1.3	<i>Accessories</i>	26

1.4 UNIT IDENTIFICATION

The electrofusion units **LITTLE BEAT** are identified by means of their own identification plate, which includes the “CE” marking, fusion control box serial number and technical specifications.

1.5 MEASURES OF PROTECTION AGAINST ACCIDENTS

1.5.1 Safety alert symbols

This User Manual employs the following safety alert symbols:



Indicates information, considered important, but not hazard-related.



When appears this hazard alert sign in this manual, carefully read what is says.



Indicates a hazardous situation that, if not avoided, will result in death or serious injury.



Indicates a hazardous situation that, if not avoided, could result in death or serious injury.



Indicates a hazardous situation that, if not avoided, could result in minor or moderate injury.

1.5.2 Safety measures and dangers

Please go by the following safety measures:

- Keep the fusion control box out of the reach of non-authorized personnel, non-qualified personnel and children. Protect the control unit from water, rain, snow, etc.
- When transporting the unit, and during loading and unloading operations, the appropriate precautionary measures must be taken to ensure that all unit components are completely secured in the vehicle, and that they are free from impact during transportation.
- Protect the electrofusion cables and the cable that goes to the power supply of cutting objects.
- All damaged cables must be replaced immediately by the After-Sales Service of STPAcuster.
- Always plug the control box to a power supply provided with differential and ground connection.
- Do not expose the fusion control box to heavy weights. All slight damage caused to the external frame or to other elements will have to be replaced immediately by the After-Sales Service of STPAcuster.

- The fusion control boxes which are not being used must be kept out of the reach of the non-authorised personnel. They will have to be kept in rooms of low humidity degrees and of restricted access.
- Always use adequate working clothes.
For outside work, it is recommended to use rubber gloves and boots with insulating soles (in wet areas, this advice is essential), and other applicable personal protective equipment such as hard hat, safety glasses, etc.
For indoor fusion jointing work, adequate ventilation of the premises must be provided.
- Before using the fusion control box, its external condition will have to be checked, as well as its working condition. All components must be correctly assembled in order to guarantee the correct functioning of the unit.
- The damaged components must be repaired or replaced by the After-Sales Service of STPAcuster.
- The fusion control box can only be opened by the After-Sales Service of STPAcuster.
- Should the fusion control box not work properly, it will have to be sent immediately to the After-Sales Service of STPAcuster.

1.6 DECLARATION "CE" OF CONFORMITY

ACUSTER GLOBAL, S.L.
 Rambla d'Ègara, 340 4th floor
 08221 Terrassa (Barcelona)
 SPAIN

declare under our sole responsibility that the electrofusion units **LITTLE BEAT**, to which this declaration relates is in conformity with the following Directives and also the following relating standards:

Directive	Related Specification	Model
2014/35/EU, Annex III Low Voltage	EN 60204-1 EN 60335-1; EN 60519-1	LITTLE BEAT
2014/30/EU, Annex I and II Electromagnetic compatibility	EN 61000-6-2 EN 61000-6-3	
2002/95/CE ROHS	EN 62321-1	
2002/96/CE WEEE		
	ISO 12176-2	
	ISO/TR 13950	

Terrassa, 2nd January 2011



Jaume Puig
 General Manager

1.7 GUARANTEE

Guarantee Declaration:

All the electrofusion units **LITTLE BEAT** are manufactured from high quality material and have been subjected to rigorous tests for resistance and working order as well as passing all the quality control tests required by the applicable normative (see "CE" Declaration of conformity).

Regardless of whether an incident might occur during the period of guarantee, we recommend careful reading of the following general guarantee conditions.

General conditions of Guarantee:

1. ACUSTER GLOBAL, S.L. guarantees that this product has no manufacturing defect at the time of its purchase and extends this guarantee for the period of 12 MONTHS.
2. If the product proves defective during this period, due to the materials or its assembly, it will be repaired free of charge, including the cost of materials and labour at STPAcuster's Technical Service.
3. The Guarantee is not valid in the following cases:

When the fault in the product is a result of:

- Abuse or incorrect use of the unit.
 - Not following the instructions specified in this *User Manual* for connecting to a group generator.
 - Not following the instructions specified in this *User Manual* for connecting to a group generator.
 - Repairs carried out without authority from STPAcuster (the taking apart or breaking of the unit's seal immediately renders the guarantee invalid)
 - Accidents, natural disasters (including lightning, water action etc) as well as any cause beyond STPAcuster's control.
4. In all claims against this guarantee, information relating to the model, date of purchase, Serial number and any other additional information must at all times be stated.

2 DESCRIPTION OF THE ELECTRONIC FUSION UNIT

2.1 GENERAL

The electrofusion units **LITTLE BEAT** are made up of a plastic case assembled inside a metal transport box which additionally serves for its protection.

The front part is formed by a membrane which incorporates tactile push-buttons to enter the data, a back-lit LCD display two indicator LEDs and a general switch.

Inside, the unit is formed by a processor board (CPU), transformer, in addition to all of the electronics necessary for the electrofusion process, current and voltage controls.



Figure 3: **LITTLE BEAT** general view

2.2 FRONT PART

The front part of **LITTLE BEAT** electrofusion unit is formed by a silkscreened plastic membrane which incorporates membrane type tactile push-buttons. The display is located on the upper right side.

Where:

General switch	With back-lit
Display	Of 16 x 2 characters
FUSION LED	Fusion indicator
POWER LED	Power indicator
START	Start push button
STOP	Stop push button
DATA	Fusion data push button (acc. to model)
OK	Validation push button
➔ and ➜	Arrows to shift menus
0 to 9	Alphanumeric push button



Figure 4

2.3 SIDES

On the right side of the **LITTLE BEAT** electrofusion unit (looking at it from the front), the following elements are located:

On the plastic casing:

- 1** Mains cable & cable gland
- 2** Electrofusion cables & cable glands
- 3** RT cable gland
- 4** Buzzer cable gland
- 5** Serial connector for scanner

On the metal casing:

CE plate with technical specifications

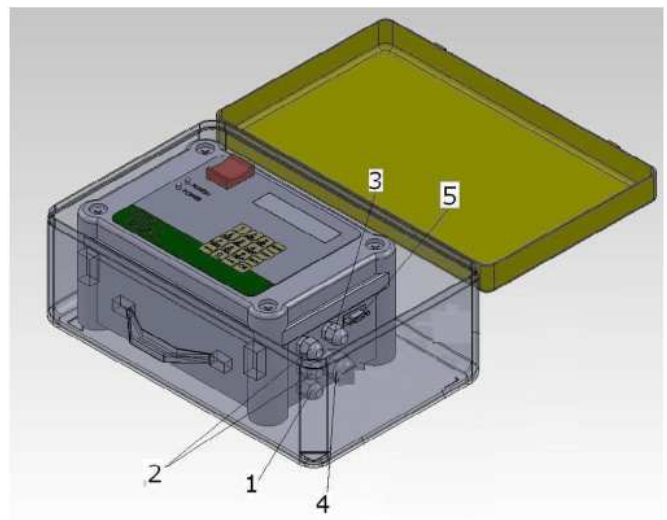

Figure 5

3 MODE OF USE

3.1 FUSION PROCEDURE FOR ELECTROFUSION FITTINGS

3.1.1 Scraping pipe surfaces

First clean the surface to be scraped with a clean lint-free dry cloth. The length to be cleaned will depend on the size of the fitting to be used, adding a minimum additional margin of 50 mm on each end.

Scrape the area of the pipe or pipes where the fitting to be joined will be installed. The length of the scraping should be greater than that of the fitting.



IMPORTANT!

The scraping of the pipe should generate swarf. This ensures the elimination of the pipe's most exterior oxidation, which would otherwise lead to a dissatisfactory electrofusion joint.

Next clean the scraped area with a de-greasing towel or with a clean, dry white cloth (which does not shed lint), dampened with isopropanol or recommended PE solvent.

3.1.2 Fitting installation

For joints of *tapping saddles* and *branch saddles*, place a rounder on each side of the scraped area if the fusion is performed over a bar pipe. If the joint is performed over a pipe from a roll, the placement of an aligner-rounder tool is indispensable. Next install the fitting over the pipe.

If the fitting to be jointed is a *coupler*, *reducer* or *elbow*, remove it from its wrapping, and without touching its interior, install it on the scraped and cleaned pipe. Now assemble the aligner and the other specially-prepared pipe or fitting.

Electrofusion joints should only be carried out by qualified staff.

Protect the area where electrofusion area carried out from adverse weather conditions, such as rain, snow or wind. Admissible temperatures range from -5°C to +40°C. In order to achieve a uniform temperature in the whole diameter of the pipes, protect the fusion area against sunrays or bad weather.

The quality of the joint depends substantially on the care taken in the previous preparation tasks (scraping, degreasing, etc).

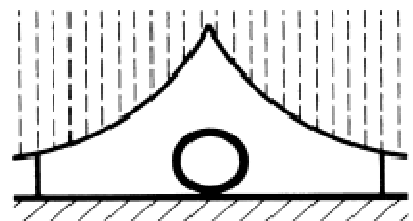

Figure 6

3.1.3 Unit connection



Connect the unit to a 230 V ± 15%/50-60 Hz mains source of alternating current. For generator group specifications, please refer To *chapter 5: TECHNICAL CHARACTERISTICS*.



IMPORTANT NOTES!

Connection to a generator: the generator electric connection where the control box mains is plugged must be normalized. Refer to the generator's User Manual.

Connection to the mains: the building electric installation where the control box mains is plugged must be fitted with a circuit breaker.

Do not unplug the mains pulling from the cable.

Checking the fitting connection cable terminals before starting up the unit is advised. There are different types of adopters depending on the type pf fitting to be used.

The switch of the unit will light, indicating that there is an electrical power input. Now turn on the switch.



NOTES!

In case to be activated the user authorization code (refer to clause 3.2.2 of this *Manual*), the display will show the following message:



Enter the PIN number corresponding to unit's the serial number.

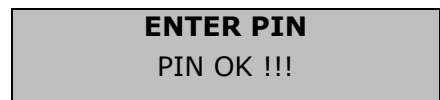

The initial screen is shown:



The display backlight will be enabled, an acoustic signal heard and the following information will appear:

LITTLE BEAT: Model
SERIALN xxx: Serial number
YYYY: manufacturing year

From software version v. 1.7.0, once the display time has elapsed (2 seconds), the unit will display the following screen

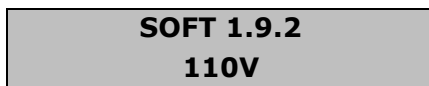

Showing the unit's software version loaded and 110V (it is displayed on 110V input voltage units only).

Once the display time has elapsed (2 seconds), the unit will display the following screen.



Press **OK** to validate this option. To access to option **2. SETTINGS**, go to clause 3.2.

3.1.4 Fitting connection

Connect the unit cable connectors in the fitting terminals to be joined. The contact surfaces of both the fitting's terminals and the cable connectors must always be clean.



NOTES!

Check that threaded adapters correspond to the diameter of the fitting terminals to fuse:

- 2 adapters of diameter 4 mm (blue colour).
- 2 adapters of diameter 4.7 mm (black colour).



It is recommended refraining from electrofusion if the exterior temperature is below -5°C or above +40°C



WARNING!

In order to guarantee a good electrofusion, it is recommendable not to reuse a fitting in which the fusion cycle has been interrupted.

3.1.5 Entering electrofusion data in the unit

Validating the previous option, appears in the display

MODE OF USE
1 MANUAL FUSION

Choose this option to carry out a manual electrofusion.

To view the 3 remaining options, click on the arrow ➡ to move to the next option and the arrow ⬅ to go back to the previous one.

MODE OF USE
2 SCANNER

Choose this option to carry out an electrofusion with scanner.

MODE OF USE
3 BARCODE

Choose this option to carry out an electrofusion using the barcode numbers.

MODE OF USE
4 LAST PARAMET.

Choose this option to carry out an electrofusion with the same parameters used in the last electrofusion.

Press the arrow ⬅ to go back to other settings or press the number directly.



If there is a malfunction in the electrofusion process, hot molten PE/PP can be expelled in rare cases. Therefore, keep at a safe distance from the fusion point during the electrofusion cycle and do not connect any other electric equipment during the process.

3.1.5.1 Manual data entry:

Is the first choice showed when validated **1 FUSION** with **OK** key.

MODE OF USE 1 MANUAL FUSION	Validate it by pressing the OK key.
----------------------------------------------	--------------------------------------------

Electrofusion voltage in a range of 8 and 44 V are only accepted.

FUSION VOLTAGE: U = 40,0 [V]	U = 40.0 V corresponds to the last entry; entry via the keyboard the desired voltage, if different.
-----------------------------------------------	-----------------------------------------------------------------------------------------------------

Validate with the **OK** key to continue or press **STOP** to go back to the previous screen.

FUSION TIME: Tf = 400s Ta=tt°C	tf = 400s corresponds to the last entry; entry via the keyboard the desired time, if different.
-------------------------------------------------	-------------------------------------------------------------------------------------------------

Ta = tt°C corresponds to the ambient temperature (for information) for correcting the electrofusion time based on this merger.

Validate with the **OK** key to continue or press **STOP** to go back to the previous screen.

COOLING TIME: tc = 11 [min]	tc = 11 corresponds to the last entry; entry via keyboard the desired cooling time, if different.
----------------------------------------------	---------------------------------------------------------------------------------------------------

Validate with the **OK** key to continue or press **STOP** to go back to the previous screen.



NOTES!

If no fitting is connected to the unit's electrofusion cable terminals, the display will show the following message "NO FITTING: CHECK WIRES!". Refer to clause 3.1.6.4 of this *Manual*.

U=40,0V tf=400s tc =11min START	The display shows the input parameters and the message START making intermittences.
--------------------------------------------------	--------------------------------------------------------------------------------------------

Press **START** to begin the electrofusion cycle. Press **STOP** to go back to screen **1 MANUAL FUSION**.

U=40,0V I=aaA tf =400 R=rrΩ	The display shows the electrofusion voltage, current and time as well as the fitting resistance.
----------------------------------------------	--------------------------------------------------------------------------------------------------

During the electrofusion cycle the **FUSION** LED blinks and the buzzer becomes audible.

Once terminated the fusion cycle, the display shows the cooling time entered:

COOLING: tc = 11 [min]	Where tc = 11:00 is the entered time. Automatically starts the countdown to the expiration of the time.
-----------------------------------------	---------------------------------------------------------------------------------------------------------

After the expiration of the cooling time, the display will show the following screen:

**END OF
FUSION !!!**

This message appears very briefly, going on to the MAIN MENU screen.

**MAIN MENU:
1 FUSION**

Press **OK** to validate this option and start again.

3.1.5.2 Fitting barcode input by scanner:

With the display in the first option **1 MANUAL FUSION**, press the arrow **➡**.

**MODE OF USE
2 SCANNER**

Choose this option to carry out an electrofusion with scanner.

Validate with the **OK** key to continue or press **STOP** to go back to the previous screen.

**UNIT IS READY
SCAN BARCODE**

Capture the fitting barcode with the scanner.



WARNING!

Make sure you always read the barcode corresponding to the fitting to be electrofused. Should you not record the fitting's data, this could cause errors in the electrofusion process that would have repercussions on the quality and reliability of the joint.

When reading, the connected scanner emits a red laser line of a particular length. To capture the barcode data, place the scanner so that the laser line coincides longitudinally with the barcode. The distance will depend on the size of the barcode to read. Once the scanner has been placed in position, the laser line will stop flashing and remain fixed. When this happens, press the button on the top of the scanner.

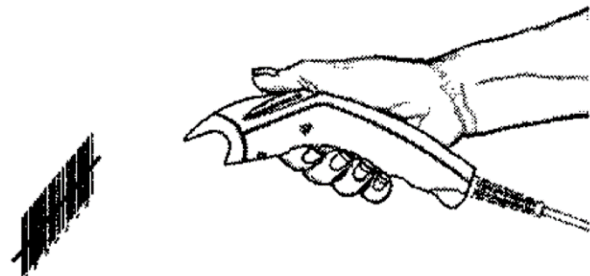

Figure 7: Example of using the laser scanner

**U=40,0V te=400s
tc =11min START**

The display shows the parameters captured by the scanner and the message **START** making intermittences.



NOTES!

If no fitting is connected to the unit's electrofusion cable terminals, the display will show the following message "NO FITTING: CHECK WIRES!". Refer to clause 3.1.6.4 of this *Manual*.

Press **START** to begin the electrofusion cycle. Press **STOP** to go back to screen **1 MANUAL FUSION**.

U=40,0V **I=aaA**
te =400 **R=rrΩ**

The display shows the electrofusion voltage, current and time as well as the fitting resistance.

During the electrofusion cycle the **FUSION** LED blinks and the buzzer becomes audible. Once terminated the fusion cycle, the display shows the cooling time entered:

COOLING:
tc = 11 [min]

Where $t_c = 11:00$ is the entered time. Automatically starts the countdown to the expiration of the time.

After the expiration of the cooling time, the display will show the following screen:

**END OF
FUSION !!!**

This message appears very briefly, going on to the MAIN MENU screen.

MAIN MENU:
1 FUSION

Press **OK** to validate this option or press the arrow **➡** to access to **2 SCANNER** to start again.

3.1.5.3 Fitting barcode input by keyboard:

With the display in the first option **1 MANUAL FUSION**, press two times the arrow ➡.

MODE OF USE
3 BARCODE

Choose this option to carry out an electrofusion entering the fitting barcode figures.

Validate with the **OK** key to continue or press **STOP** to go back to the previous screen.



WARNING!

Make sure you always read the barcode corresponding to the fitting to be electrofused. Should you not record the fitting's data, this could cause errors in the electrofusion process that would have repercussions on the quality and reliability of the joint.

NNNNNNNNNNNN
NNNNNNNNNNNN

Through the keyboard, enter the 24-digit bar code of the fitting to be fused.

Validate with the **OK** key to continue or press **STOP** to go back to the previous screen.

U=40,0V **te=400s**
tc=11min **START**

The display shows the parameters manually entered and the message **START** making intermittences.



NOTES!

If no fitting is connected to the unit's electrofusion cable terminals, the display will show the following message "NO FITTING: CHECK WIRES!". Refer to clause 3.1.6.4 of this *Manual*.

Press **START** to begin the electrofusion cycle. Press **STOP** to go back to screen **1 MANUAL FUSION**.

U=40,0V **I=aaA**
te=400 **R=rrΩ**

The display shows the electrofusion voltage, current and time as well as the fitting resistance.

During the electrofusion cycle the **FUSION** LED blinks and the buzzer becomes audible. Once terminated the fusion cycle, the display shows the cooling time entered

COOLING:
tc= 11:00

Where $t_f = 11:00$ is the entered time. Automatically starts the countdown to the expiration of the time.

After the expiration of the cooling time, the display will show the following screen:

END OF
FUSION !!!

This message appears very briefly, going on to the **MAIN MENU** screen.

MAIN MENU
1 FUSION

Press **OK** to validate this option or press two times the arrow ➡ to access to **3 BARCODE** to start again.

3.1.5.4 Using the fitting electrofusion parameters entered in the last fusion:

With the display in the first option **1 MANUAL FUSION**, press three times the arrow ➡.

MODE OF USE:
4 LAST PARAMET.

Choose this option to carry out an electrofusion using the same fitting parameters entered in the last fusion.

Validate with the **OK** key to continue or press **STOP** to go back to the previous screen.

U=40,0V **te=400s**
tc=11min **START**

The display shows the parameters entered and the message **START** making intermittences.



NOTES!

If no fitting is connected to the unit's electrofusion cable terminals, the display will show the following message "NO FITTING: CHECK WIRES!". Refer to clause 3.1.6.4 of this *Manual*.

Press **START** to begin the electrofusion cycle. Press **STOP** to go back to screen **1 MANUAL FUSION**.

U=40,0V **I=aaA**
te=400 **R=rrΩ**

The display shows the electrofusion voltage, current and time as well as the fitting resistance.

During the electrofusion cycle the **FUSION** LED blinks and the buzzer becomes audible. Once terminated the fusion cycle, the display shows the cooling time entered:

COOLING
tc= 11:00

Where $t_c = 11:00$ is the entered time. Automatically starts the countdown to the expiration of the time.

After the expiration of the cooling time, the display will show the following screen:

END OF
FUSION !!!

This message appears very briefly, going on to the **MAIN MENU** screen.

MAIN MENU:
1 FUSION

Press **OK** to validate this option or press three times the arrow ➡ to access to **4 LAST PARAMET.** to start again.

3.1.6 Incidents that may occur

3.1.6.1 Input voltage out of range:

If at the start or during the electrofusion cycle the input voltage is less than 200Vac, the cycle of electrofusion stops and the following message is displayed:

**VOLTAGE IS TOO
LOW << 200 V**

This message appears very briefly going on to the initial START MENU screen.

3.1.6.2 Electrofusion voltage out of range:

If the electrofusion voltage of the barcode fitting captured by the scanner via option **2 SCANNER**, or entered manually through the option **3 BARCODE**, is less than 8 V or greater than 44 V, the following message is displayed:

**VOLTAGE TOO LOW
U < 8.0 V**

This message appears very briefly going on to the initial START MENU screen.

**VOLTAGE TOO HIGH
U > 44.0 V**

This message appears very briefly going on to the initial START MENU screen.

3.1.6.3 Incorrect barcode or poorly captured:

If it is done an incorrectly capture of the barcode through the scanner, the display shows the following message:

**READING OF CODE
IS IMPOSSIBLE**

This message appears very briefly going on to the following next screen:

**ENTER PARAMETERS
IN MANUAL MODE**

This message appears very briefly going on to the screen MODE OF WORK: 1 MANUAL WORK:

If it is done a barcode captures that is incorrect or is manually entered incomplete or in a incorrect way, the display shows the following message:

**BAR CODE IS
NOT CORRECT**

This message appears very briefly. If entered manually, it is displayed the following screen:

**ENTER BAR CODE
FROM KEYBOARD**

This message appears very briefly going on to the barcode introduction screen.

3.1.6.4 Fitting unplugged or problems with the adapters or the fitting:

In the case that the fitting is not connected or it is detected that the electrofusion wires are not well connected (e.g. wrong size adapters), fitting failure (resistance cut), the following message is displayed:

**NO FITTING
CHECK WIRES!**

Up to software version 8.1.2 this message appears very briefly going on to the initial START MENU screen.



NOTES!

From software version 1.8.3 this message stays on the screen intermittently, accompanied by the buzzer until the unit detects a closed circuit or it is turned off via the power switch.

3.1.6.5 High internal temperature:

When during the electrofusion cycle there is a transformer overheating ($> 70^{\circ}\text{C}$), a safety device allows to end the cycle but prevents to carry out the next electrofusion until the internal temperature has dropped sufficiently (the **START** button is disabled). The following message appears:

**TRAFO TEMP.
TOO HIGH**

This message appears very briefly going on to the initial START MENU screen

3.1.6.6 Outside temperature too low:

When the ambient temperature is below -5°C , the following message is displayed:

**TEMPERAT. = tt°C
NO FUSION !!!**

Where **tt** is the ambient temperature -6°C or lower.

Locate the unit in an area where the ambient temperature is higher than indicated.

3.1.6.7 Detection of open circuit or incident:

If during the electrofusion cycle an incident occurs, such as disconnecting an electrofusion terminal or terminals, the unit detects a magnetic field, fitting failure (cross spirals), the demanded power exceeds the unit features (50 A up to software version 1.5.0 and 65 A from software version 1.6.0), the following message is displayed:

**SHORT-CIRCUIT
OR ACCIDENT**

This message appears very briefly going on to the initial START MENU screen.

3.1.6.8 Cooling phase:

The time of the cooling phase should be greater than zero. Otherwise the following message is displayed:

**THE TIME
MUST BE > 0**

This message appears very briefly going on to the original input screen cooling time.

If the cooling phase is interrupted by pressing **STOP**, the following message is displayed

**STOP COOLING?
1 = YES 2 = NO**

Pressing **2**, the unit returns to the cooling phase; pressing **1** will abort the cooling.

**COOLING HAS
JUST BROKEN**

This message appears very briefly going on to the initial START MENU screen.

3.1.6.9 Interruption by the operator:

Pressing **STOP** during the electrofusion cycle the following message is displayed:

FUSION HAS JUST BROKEN	This message appears very briefly going on to the initial START MENU screen.
-----------------------------------	------------------------------------------------------------------------------

3.2 ACCESS TO SETUP MENU

With the unit connected to a power source, activate the general switch. Once expired the time information exposure (about 2 seconds), the unit will display the following screen:

MAIN MENU: 1 FUSION	To access to setup menu, press the arrow ➡.
--------------------------------	---------------------------------------------

MAIN MENU: 2 SETTINGS	Press OK to validate or press the arrow ◀ to go back to the previous screen .
----------------------------------	--------------------------------------------------------------------------------------

Validating the previous option, the display will show:

SETTINGS: 1 DISPLAY	Choose this option to set the backlight and contrast.
--------------------------------	-------------------------------------------------------

To access to the 3 remaining options, click on the arrow ➡ to move to the next option and the arrow ◀ to go back to the previous.

SETTINGS: 2 PIN CODE	Choose this option to enter the user authorization PIN code.
---------------------------------	--------------------------------------------------------------

SETTINGS: 3 LANGUAGE	Choose this option to change the language .
---------------------------------	---------------------------------------------

SETTINGS: 4 SERVICE	This option is restricted to the Service Centres.
--------------------------------	---------------------------------------------------

Press the arrow ◀ to go back to the other options

3.2.1 Display settings:

It is the first choice that is showed when validated **2 SETTINGS** by pressing **OK**.

BACKLIGHT 1->ON 2->OFF	Press 1 to activate the backlight and 2 to deactivate.
-----------------------------------------	----------------------------------------------------------------------

Press **OK** to move to the next screen and **STOP** to go to the previous screen.

CONTRAST 0 % 1-> ↓ 2- ↑	Press 1 to increase the contrast and 2 to decrease (each pulse is 2%).
---------------------------------------	--------------------------------------------------------------------------------------

Press **OK** to exit this menu

3.2.2 Activation of the user authorization code:

Once validated **2 SETTINGS** by pressing **OK**, press the arrow **➡** to access to this option. Press the arrow **⬅** to go back to the previous one.

PIN ENABLE:
1=YES 2=NO

Press **1** to activate the authorization code and **2** to deactivate it.

Pressing either **1** as **2** goes to the setting screen **1 DISPLAY**.

Press **STOP** to exit this menu.



NOTES!

To enable this option, you will need from now an access code number which is individual for each unit. Before you activate, apply for the PIN number corresponding to the unit's serial number to Acuster Global.

3.2.3 Language settings:

Once validated **2 SETTINGS** by pressing **OK**, press two times the arrow **➡** to access to this option. Press the arrow **⬅** to go back to the previous one

LANGUAGE
1 ENGLISH

Pressing the arrow **➡** accesses the currently loaded languages. Press the arrow **⬅** to go back to the previous.

Once displayed the desired language, press **OK** to validate or **STOP** to exit without changing the language.

3.2.4 Service menu:

Once validated **2 SETTINGS** by pressing **OK**, press three times the arrow **➡** to access to this option. Press the arrow **⬅** to go back to the previous one.

ENTER PIN:

This option is restricted to the Service Centres.

If you want to exit this option without entering the access PIN code, turn the unit off via the general switch.

4 MAINTENANCE

4.1 GENERAL

4.1.1 Introduction:

The electrofusion units **LITTLE BEAT** have been designed and manufactured for a long-life service without the need for costly repairs and adjustments. All that is required is careful handling when loading/unloading and during transportation, and in general to keep the unit clean by following the recommended preventive maintenance. The costs are very low and are soon written off given that the unit will be fully functional at all times.

This section includes a list of general upkeep and maintenance routine operations. Should any problem arise please refer to clause **3.1.6: Incidents that may occur** in this *User Manual*. However, no action should be taken by unqualified personnel beyond these troubleshooting measures in order not to run the risk of seriously damaging the unit.

4.1.2 Storage:

If the unit is not to be used for a long period of time, keep it in its original packing and protected from dust, moisture, extremes of temperatures, direct sunlight, and so on. The electrofusion control box could be stored either on the warehouse floor or in pallet racks.

4.1.3 Cleaning:

Clean the electrofusion control box regularly using only a damp cloth.

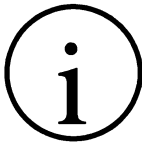

NOTE!

Do not clean the electrofusion control box with water under pressure, by immersion in water or with compressed air.

Do not rub excessively the plastic shell, for it could charge itself with static electricity.

Should the unit be very dirty, clean it with a bit of alcohol (do not use solvents or cleaning products containing trichloroethylene).

4.1.4 Services:

We recommend shipping the electrofusion control unit to the STPAcuster group authorized distributor, for a minimum yearly service.

4.2 CONTROL UNIT MAINTENANCE

4.2.1 Electronic Control Unit:

Besides the exterior cleaning of the casing, there is no specific maintenance for the electronic control unit. Tune-ups and adjustments should be performed by qualified personnel, or by the STPAcuster's After-Sales Service.

4.2.2 Updating the Programme Version:

The updating of the **LITTLE BEAT** electrofusion unit software must be performed exclusively by the STPAcuster's After-Sales Service.

5 TECHNICAL CHARACTERISTICS

5.1 ELECTROFUSION CONTROL UNIT

5.1.1 General specifications:

		LITTLE BEAT	
Classification acc to ISO 12176-2	P ₂ US ₁ VKAX		
Configuration options	Language > Multilingual (request available languages)		
	Display > backlight and contrast		
Input voltage	Nominal voltage: 230 Vac ±10%	Nominal voltage: 110 Vac +20/-10%	
Input frequency	Nominal frequency: 50 Hz ±10%	Nominal frequency: 50-60 Hz	
Electrofusion voltage*	8 to 44 Vac galvanically separated		
Power consumption	2500 W maximum The fitting resistance must not be lower than 0.7 Ω (230V) or 0.8 Ω (110V)		
Generator output performance	3.0 kVA unipolar operation; electronic regulation		
Protection type	Double isolation IP55		
Duty factor	40 to 90% (depending on the fitting size) Electronic temperature monitoring of the unit		
Working temperature	-5 to 40°C (blocking at ≤ -6°C)		
Display	LCD, 2 lines x 16 characters backlight		
Acoustic warning	Piezoelectric buzzer		
Enter fusion data	Manual	Voltage: Multivoltage (steps of 0.1 V) Time: 1 to 5,000 seconds Cooling time: 1 to 99 minutes	
	Automatic	Barcode acc. to ISO/TR 13950	
Front and keys	Green/grey silkscreen plastic membrane with tactile push buttons		
Power cable	230V	2x1 mm ² (Schuko + French type plug) 2.5 m long	
	110V	3x1.5 mm ² (NEMA 5-15P type plug) 2.5 m long	
Electrofusion cables	1x10 mm ² , 3 m long (threaded terminals for adapters)		
Scanner	Laser scanner optional		
Connection of scanner	9-pins RS-232		
Accessories	Set of 4 and 4.7 mm electrofusion adapters		
Weight and dimensions	Height: 390 mm; Width: 240 mm; Length: 160 mm Nett weight: 13 kg		

* From software version v. 1.9.0 (previous versions from 10 to 42 V)

5.1.2 Generator specifications:

Frequency	:	50 Hz
Output power	:	4 kVA (minimum)
Voltage	:	230 Vac
Intensity	:	12 A (min) for 230 Vac
Voltage control	:	Preferably electronic

5.1.3 Accessories:

List of accessories included in the unit:

<u>QTY</u>	<u>DESCRIPTION</u>
1	User manual (Memory stick)
1	Scanner (optional)
2	Ø 4 mm terminal adapter
2	Ø 4.7 mm terminal adapter

